

Features

- ESD protection for two lines with bi-directional
- Provide transient protection for each line to **IEC 61000-4-2 (ESD) $\pm 30\text{kV}$ (air), $\pm 30\text{kV}$ (contact)**
- **IEC 61000-4-5 (Lightning) 2.3A (8/20 μs)**
- **Ultra-low capacitance: 0.9pF typical**
- Suitable for, 24V and below, operating voltage applications
- Fast turn-on and low clamping voltage
- Array of ESD rated equivalent TVS diodes
- Small package saves board space
- Solid-state silicon-avalanche and active circuit triggering technology
- **Green part**
- **OPEN Alliance IEEE 100/1000BASE-T1**
- **AEC-Q101 qualified**

Applications

- Automotive network protection:
 - OPEN Alliance IEEE 100/1000BASE-T1 Ethernet
- Automotive backbone communications
- Gateway
- Infotainment
- Industrial control

Description

AZ9400-02S is a design which includes two bi-directional ESD rated clamping cells to protect high-speed data interfaces. The AZ9400-02S has been specifically designed to protect sensitive components which are connected to data and transmission lines from over-voltage caused by

Electrostatic Discharging (ESD), Lightning, and Cable Discharge Event (CDE).

AZ9400-02S is a unique design which includes proprietary clamping cells in a small package. During transient conditions, the proprietary clamping cells prevent over-voltage on the data and control lines, protecting any downstream components.

AZ9400-02S may be used to meet the ESD immunity requirements of IEC 61000-4-2, Level 4 ($\pm 15\text{kV}$ air, $\pm 8\text{kV}$ contact discharge).

Circuit Diagram / Pin Configuration

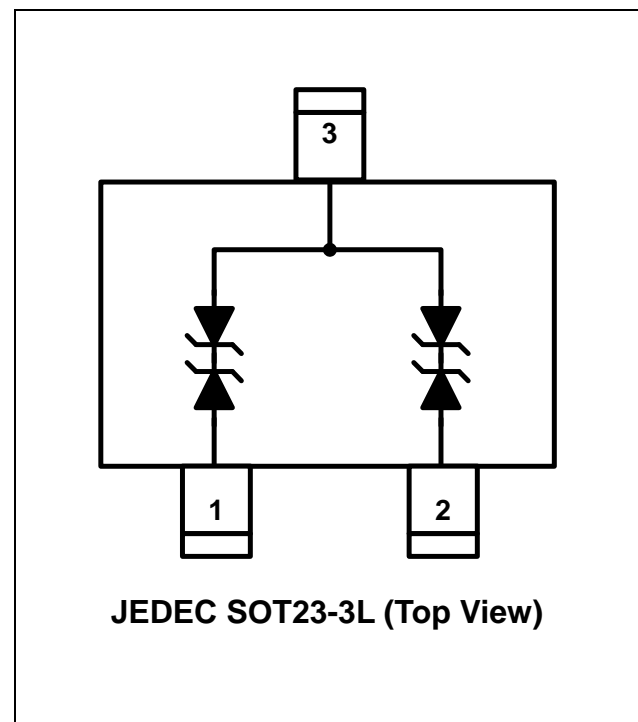



Specifications

Absolute Maximum Ratings			
Parameter	Symbol	Rating	Unit
Peak Pulse Current ($t_p=8/20\mu s$)	I_{PP}	2.3	A
Operating Voltage (I/O pin-GND)	V_{DC}	± 26.4	V
ESD per IEC 61000-4-2 (Air)	V_{ESD-1}	± 30	kV
ESD per IEC 61000-4-2 (Contact)	V_{ESD-2}	± 30	
1000 contact discharges (ISO 10605 150pF/330 Ω); OPEN Alliance specification	V_{ESD-3}	± 15	kV
ESD per ISO 10605 150pF/2k Ω (Contact)	V_{ESD-4}	± 30	kV
ESD per ISO 10605 330pF/330 Ω (Contact)	V_{ESD-5}	± 30	kV
ESD per ISO 10605 330pF/2k Ω (Contact)	V_{ESD-6}	± 30	kV
Lead Soldering Temperature	T_{SOL}	260 (10 sec.)	$^{\circ}C$
Operating Temperature	T_{OP}	-55 to +125	$^{\circ}C$
Storage Temperature	T_{STO}	-55 to +150	$^{\circ}C$

Specifications

Electrical Characteristics						
Parameter	Symbol	Condition	Min	Typ	Max	Unit
Reverse Stand-Off Voltage	V_{RWM}	Pin-1, -2 to pin-3, T=25°C.	-24		24	V
Reverse Leakage Current	I_{Leak}	$V_{RWM} = \pm 24V$, pin-1, -2 to pin-3, T=25°C.			100	nA
Reverse Breakdown Voltage	V_{BV}	$I_{BV} = 1mA$, pin-1, -2 to pin-3, T=25°C.	100			V
ESD Trigger Voltage (Note 1)	V_{t-ESD}	Pin-1, -2 to pin-3, T=25°C.	100			V
ESD Clamping Voltage (Note 1)	V_{CL-ESD}	IEC 61000-4-2 +8kV ($I_{TLP} = 16A$), contact mode, pin-1, -2 to pin-3, T=25°C.		50		V
ESD Dynamic Turn-on Resistance	$R_{dynamic}$	IEC 61000-4-2 0~+8kV, contact mode, pin-1, -2 to pin-3, T=25°C.		0.6		Ω
Channel Input Capacitance	C_{IN}	$V_R = 0V$, f = 1MHz, pin-1, -2 to pin-3, T=25°C.		0.9	1.1	pF
		$V_R = 0V$, f = 1MHz, pin-1, -2 to pin-3, T=125°C.			2	pF

Note 1: ESD Clamping Voltage and ESD Trigger Voltage were measured by Transmission Line Pulsing (TLP) System. TLP conditions: $Z_0 = 50\Omega$, $t_p = 100ns$, $t_r = 1ns$.

Typical Characteristics

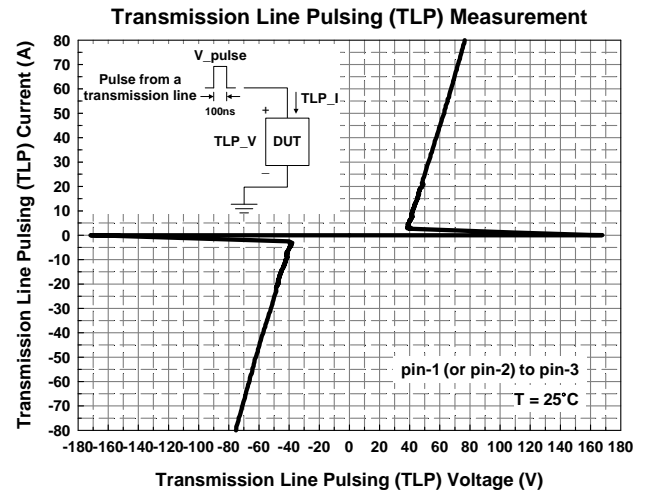
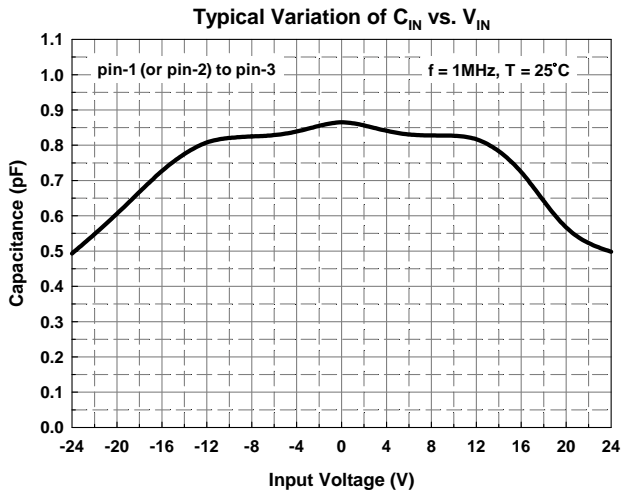

Application Information

The AZ9400-02S is designed to protect two lines against system ESD pulses by clamping it to an acceptable reference.

The usage of the AZ9400-02S is shown in Fig. 1. Protected lines, such as data lines, control lines, or power lines, are connected to pin 1 and pin 2, respectively. The pin 3 is connected to a ground plane on the board. In order to minimize parasitic inductance in the board traces, all path lengths connected to the pins of AZ9400-02S should be kept as short as possible.

In order to obtain enough suppression of ESD induced transient, a good circuit board is

critical. Thus, the following guidelines are recommended:

- Minimize the path length between the protected lines and the AZ9400-02S.
- Place the AZ9400-02S near the input terminals or connectors to restrict transient coupling.
- The ESD current return path to ground should be kept as short as possible.
- Use ground planes whenever possible.
- NEVER route critical signals near board edges and near the lines which the ESD transient easily injects to.

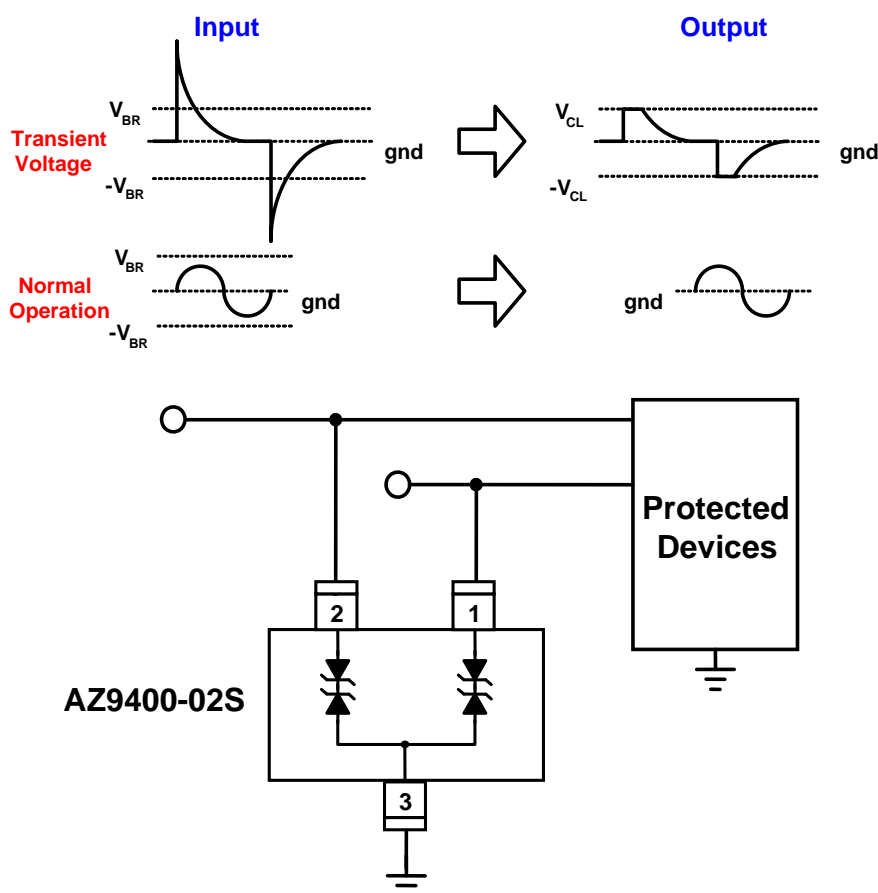

Fig. 1 The ESD protection scheme by using AZ9400-02S.

AZ9400-02S is specifically designed for protecting automotive in-vehicle network lines from over-voltage caused by ESD and transients. The ESD protection scheme for Automotive Ethernet application is shown in Fig. 2.

suppression devices mounted on test boards simulating the real environment in Automotive Ethernet application. The AZ9400-02S has been successfully passed all tests and complied with the requirements specified in the documents of "IEEE 100BASE-T1 / 1000BASE-T1 EMC Test Specification for ESD Suppression Devices". The test report with all details and graphs is available on request.

In the documents of "IEEE 100BASE-T1 / 1000BASE-T1 EMC Test Specification for ESD Suppression Devices", the OPEN Alliance describes four different tests with the ESD

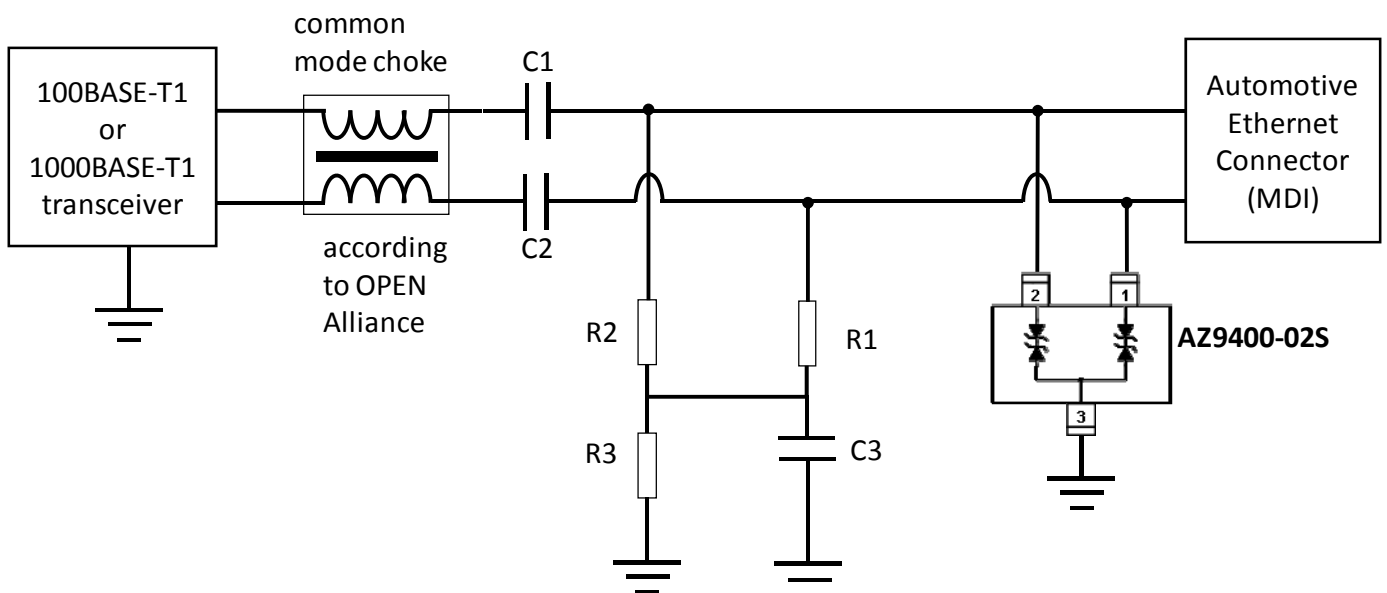
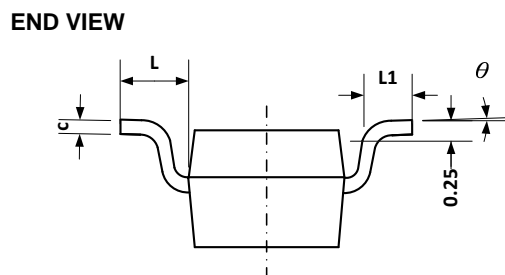
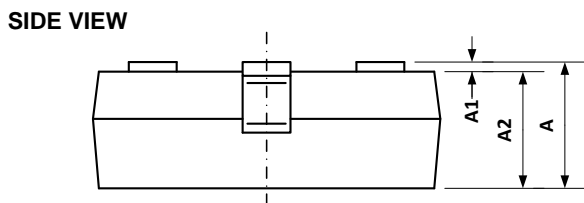
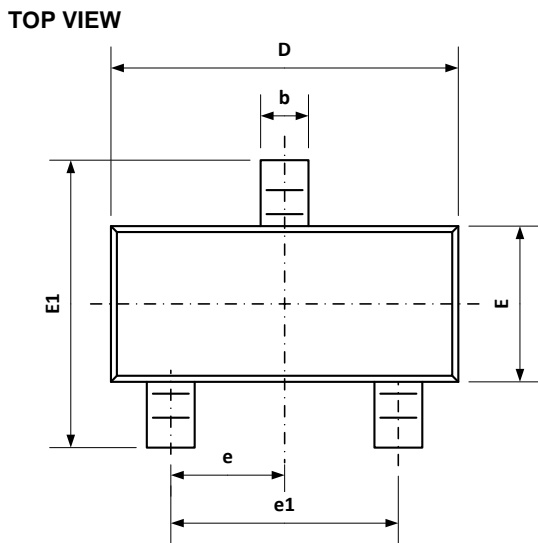

Fig. 2

Mechanical Details

SOT23-3L Package Diagrams



Package Dimensions

Symbol	Millimeters	
	Min	Max
A	0.90	1.15
A1	0.00	0.10
A2	0.90	1.05
b	0.30	0.50
c	0.08	0.15
D	2.80	3.00
E	1.20	1.40
E1	2.25	2.55
e	0.95 TYP	
e1	1.80	2.00
L	0.55 REF	
L1	0.30	0.50
θ	0	8

Land Layout

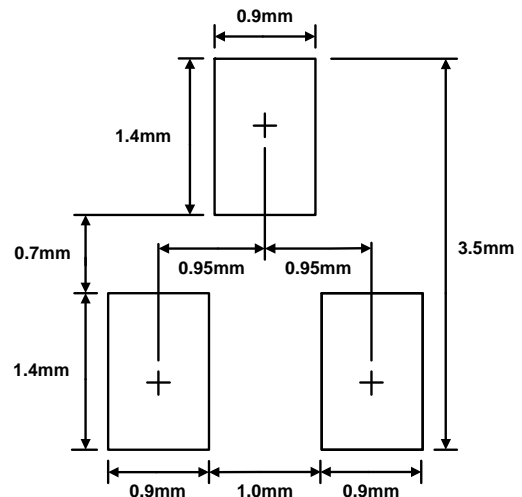

Notes:

This LAND LAYOUT is for reference purposes only. Please consult your manufacturing partners to ensure your company's PCB design guidelines are met.

Marking Code

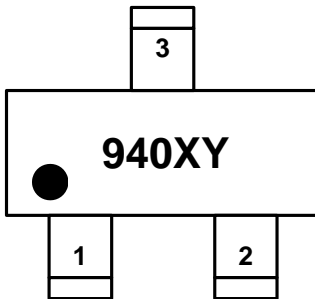

940 = Device Code
X = Date Code
Y = Control Code

Part Number	Marking Code
AZ9400-02S.R7G (Green Part)	940XY

Note. Green means Pb-free, RoHS, and Halogen free compliant.

Ordering Information

PN#	Material	Type	Reel size	MOQ	MOQ/internal box	MOQ/carton
AZ9400-02S.R7G	Green	T/R	7 inch	3,000/reel	4 reels=12,000/box	6 boxes=72,000/carton

Revision History

Revision	Modification Description
Revision 2023/11/24	Preliminary Release.
Revision 2024/10/29	Formal Release.