

Features

- ESD protection for one line with uni-directional
- Provide transient protection for each line to
IEC 61000-4-2 (ESD) $\pm 22\text{kV}$ (air / contact)
IEC 61000-4-4 (EFT) $\pm 50\text{A}$ (5/50ns)
IEC 61000-4-5 (Lightning) 6.5A (8/20 μs)
- Suitable for, **20V and below**, operating voltage applications
- **0201 small MCSP package** saves board space
- Protect one I/O line or one power line
- Fast turn-on and low clamping voltage
- Solid-state silicon-avalanche and active circuit triggering technology
- **Green part**

Applications

- Power supply protection
- USB power delivery
- Small panel modules
- Handheld portable applications
- Low speed data or control line protection
- Peripherals
- Consumer electronics

Description

AZ4U20-01M is a design which includes a uni-directional surge rated clamping cell to protect one power line, or one control line, or one low speed data line in an electronic system. The AZ4U20-01M has been specifically designed to protect sensitive components which are connected to power and control lines from

over-voltage damage caused by Electrostatic Discharging (ESD), Electrical Fast Transients (EFT), Lightning, and Cable Discharge Event (CDE).

AZ4U20-01M is a unique design which includes proprietary clamping cell in a single package. During transient conditions, the proprietary clamping cell prevents over-voltage on the power line or control/data lines, protecting any downstream components.

AZ4U20-01M may be used to meet the ESD immunity requirements of IEC 61000-4-2, Level 4 ($\pm 15\text{kV}$ air, $\pm 8\text{kV}$ contact discharge).

Circuit Diagram / Pin Configuration

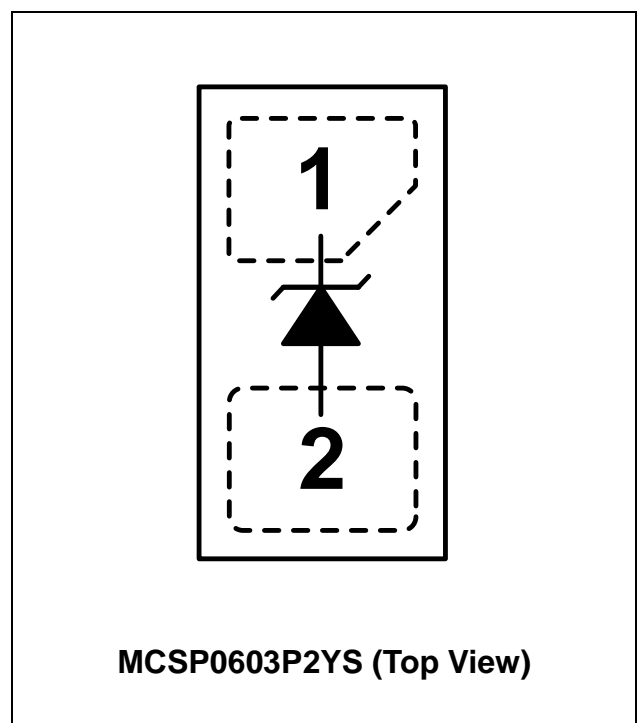



Specifications

| Absolute Maximum Ratings (T _A = 25°C, unless otherwise specified) | | | |
|--|--------------------|---------------|------|
| Parameter | Symbol | Rating | Unit |
| Peak Pulse Current (t _p =8/20μs) (Note 1) | I _{PP} | 6.5 | A |
| Operating Voltage | V _{DC} | 22 | V |
| ESD per IEC 61000-4-2 (Air) | V _{ESD-1} | ±22 | kV |
| ESD per IEC 61000-4-2 (Contact) | V _{ESD-2} | ±22 | |
| Lead Soldering Temperature | T _{SOL} | 260 (10 sec.) | °C |
| Operating Temperature | T _{OP} | -55 to +125 | °C |
| Storage Temperature | T _{STO} | -55 to +150 | °C |

| Electrical Characteristics | | | | | | |
|---------------------------------|-----------------------|---|------|------|------|------|
| Parameter | Symbol | Condition | Min | Typ | Max | Unit |
| Reverse Stand-Off Voltage | V _{RWM} | Pin-1 to pin-2, T=25 °C. | | | 20 | V |
| Reverse Leakage Current | I _{Leak} | V _{RWM} = 20V, T=25 °C, pin-1 to pin-2. | | | 0.1 | μA |
| Reverse Breakdown Voltage | V _{BV} | I _{BV} = 1mA, T=25 °C, pin-1 to pin-2. | 22.1 | | 26.5 | V |
| Forward Voltage | V _F | I _F = 15mA, T=25 °C, pin-2 to pin-1. | 1 | | 2 | V |
| Surge Clamping Voltage (Note 1) | V _{CL-surge} | I _{PP} = 6.5A, t _p = 8/20μs, T=25°C. | | 29 | | V |
| ESD Clamping Voltage (Note 2) | V _{CL-ESD} | IEC 61000-4-2 +8kV (I _{TLP} = 16A), contact mode, T=25 °C, pin-1 to pin-2. | | 28.5 | | V |
| ESD Dynamic Turn-on Resistance | R _{dynamic} | IEC 61000-4-2 0~+8kV, T=25 °C, contact mode, pin-1 to pin-2. | | 0.28 | | Ω |
| Channel Input Capacitance | C _{IN} | V _R = 0V, f = 1MHz, pin-1 to pin-2, T=25 °C. | | 15 | 20 | pF |

Note 1: The Peak Pulse Current measured conditions: t_p = 8/20μs, 2Ω source impedance.

Note 2: ESD Clamping Voltage was measured by Transmission Line Pulsing (TLP) System.

TLP conditions: Z₀= 50Ω, t_p= 100ns, t_r= 1ns.

Typical Characteristics

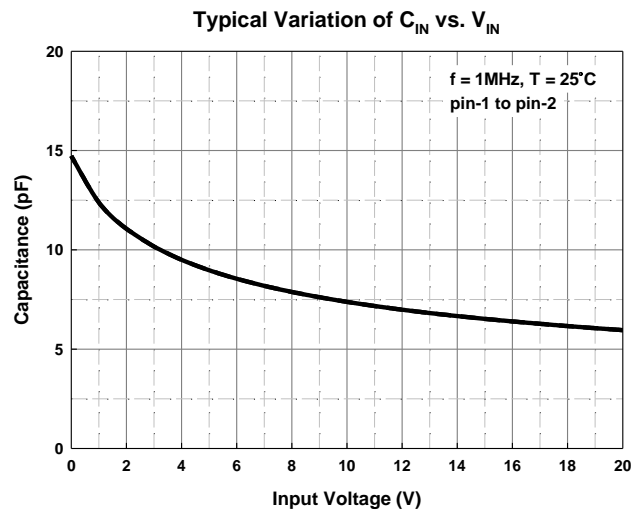
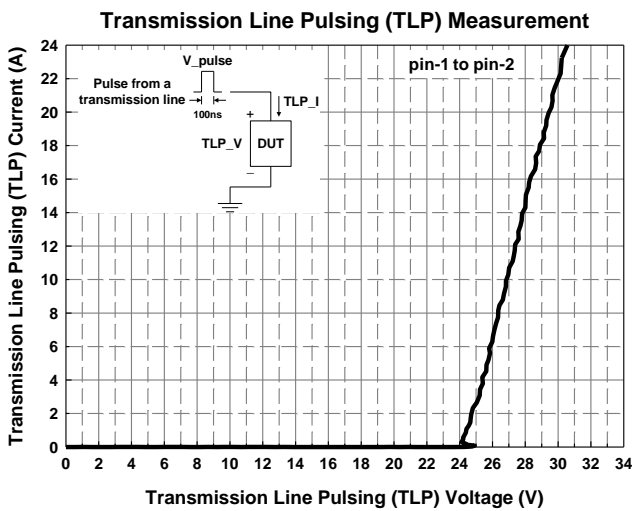
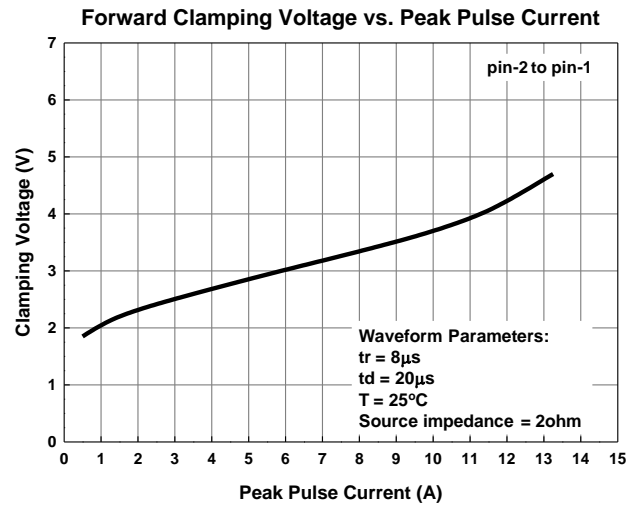
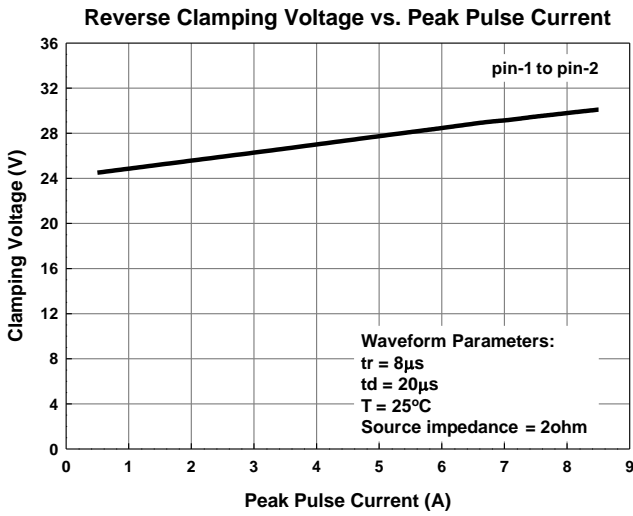

Applications Information

The AZ4U20-01M is designed to protect one line against system ESD / EFT / Lightning pulses by clamping it to an acceptable reference.

The usage of the AZ4U20-01M is shown in Fig. 1. Protected lines, such as data lines, control lines, or power lines, are connected to pin 1. The pin 2 should be connected directly to a ground plane on the board. All path lengths connected to the pins of AZ4U20-01M should be kept as short as possible to minimize parasitic inductance in the board traces.

In order to obtain enough suppression of ESD induced transient, a good circuit board is critical. Thus, the following guidelines are recommended:

- Minimize the path length between the protected lines and the AZ4U20-01M.
- Place the AZ4U20-01M near the input terminals or connectors to restrict transient coupling.
- The ESD current return path to ground should be kept as short as possible.
- Use ground planes whenever possible.
- NEVER route critical signals near board edges and near the lines which the ESD transient easily injects to.

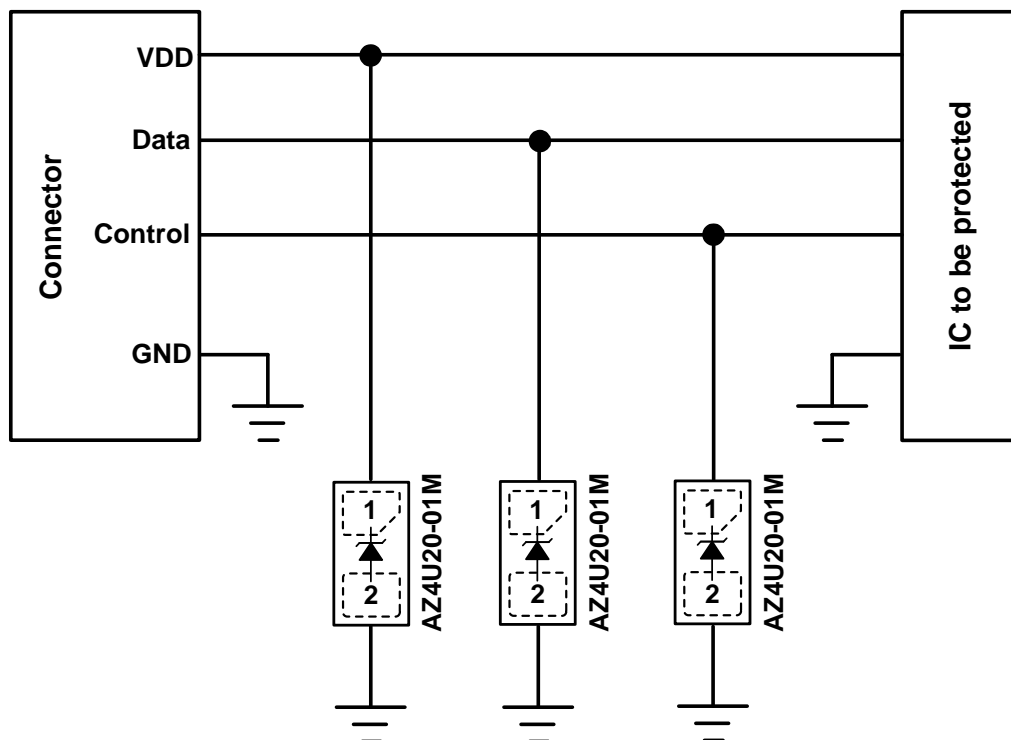
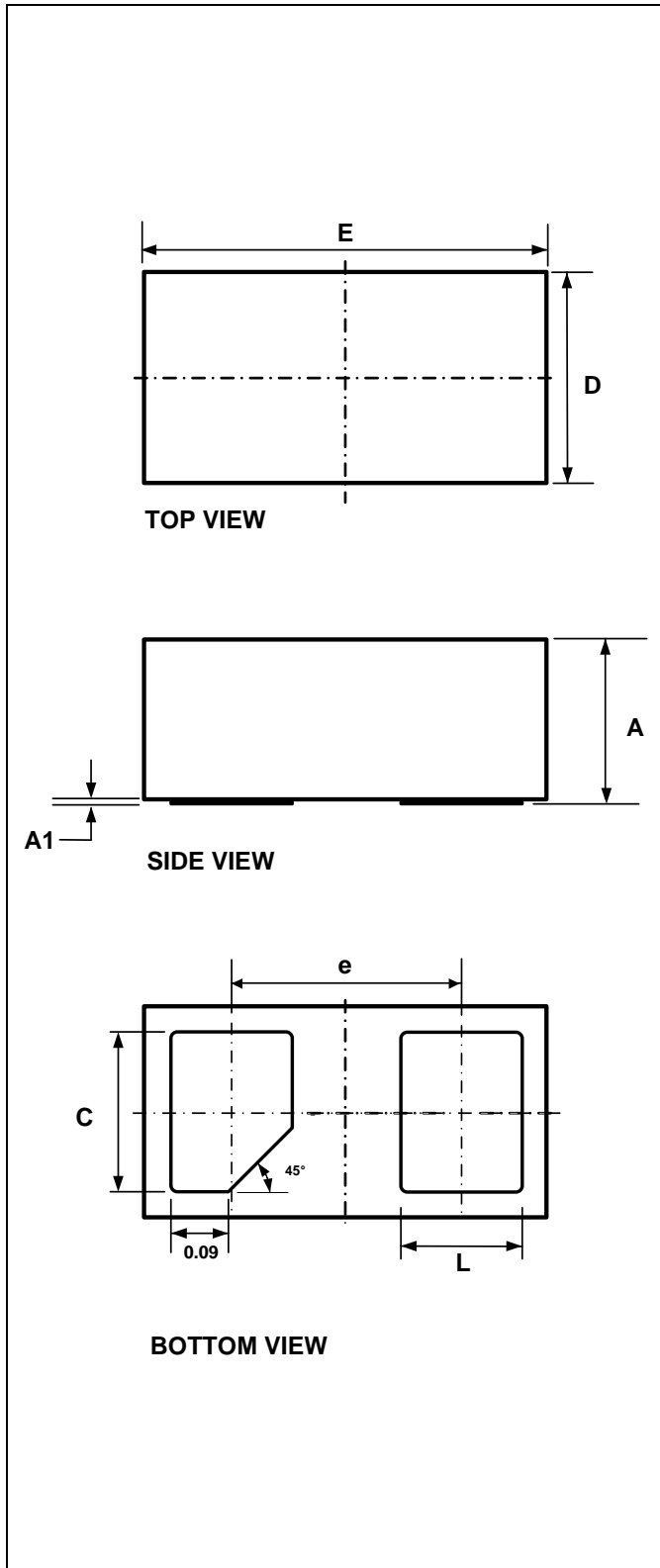

Fig. 1

Mechanical Details

MCSP0603P2YS Package Diagrams



Package Dimensions

| SYMBOL | MILLIMETERS | | |
|--------|-------------|-------|-------|
| | MIN. | NOM. | MAX. |
| E | 0.615 | 0.630 | 0.645 |
| D | 0.315 | 0.330 | 0.345 |
| A | 0.235 | 0.250 | 0.265 |
| A1 | 0.005 | 0.015 | 0.050 |
| L | 0.170 | 0.190 | 0.210 |
| C | 0.230 | 0.250 | 0.270 |
| e | 0.360 BSC | | |

Land Layout

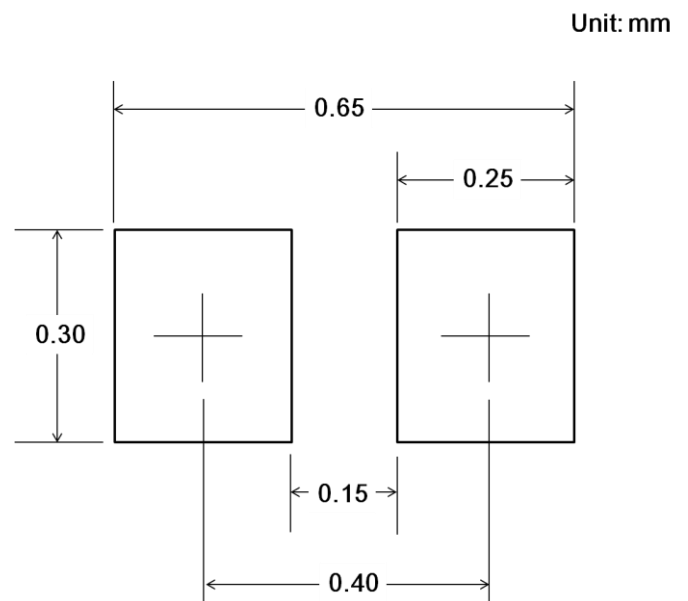

Notes:

This LAND LAYOUT is for reference purposes only. Please consult your manufacturing partners to ensure your company's PCB design guidelines are met.

Marking Code

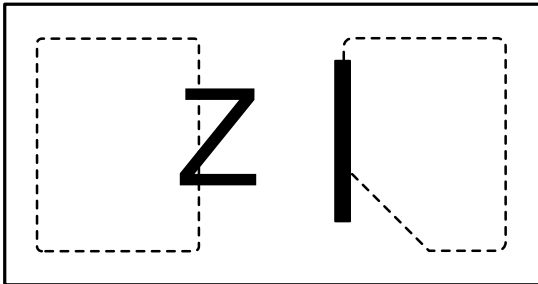

Z= Device Code

| Part Number | Marking Code |
|--------------------------------|--------------|
| AZ4U20-01M.R7G (Green Part) | Z |

Note : Green means Pb-free, RoHS, and Halogen free compliant.

Ordering Information

| PN# | Material | Type | Reel size | MOQ | MOQ/internal box | MOQ/carton |
|----------------|----------|------|-----------|-------------|----------------------|--------------------------|
| AZ4U20-01M.R7G | Green | T/R | 7 inch | 15,000/reel | 4 reels = 60,000/box | 6 boxes = 360,000/carton |

Revision History

| Revision | Modification Description |
|---------------------|--------------------------|
| Revision 2025/05/14 | Preliminary Release. |
| Revision 2025/09/25 | Formal Release. |
| | |
| | |
| | |
| | |