



## Features

- ESD/EFT/Surge Protection for 1 Line with Bi-directional
- Provide ESD protection for each line to IEC 61000-4-2 (ESD)  $\pm 30\text{kV}$  (air / contact)  
IEC 61000-4-4 (EFT) 80A (5/50ns)  
IEC 61000-4-5 (Lightning) 7A (8/20 $\mu\text{s}$ )
- Suitable for, **7V and below**, operating voltage applications
- **0201 small CSP package** saves board space
- Protect one I/O line or one power line
- Fast turn-on and Low clamping voltage
- Solid-state silicon-avalanche and active circuit triggering technology
- **Green part**

## Applications

- Mobile Phones
- Hand Held Portable Applications
- Computer Interfaces Protection
- Microprocessors Protection
- Serial and Parallel Port Protection
- Control Signal Lines Protection
- Power Lines on PCB Protection
- Latchup Protection

## Description

AZ4A07-01B is a design which includes a bi-directional ESD rated clamping cell to protect one power line, or one control line, or one low speed data line in an electronic systems. The AZ4A07-01B has been specifically designed to protect sensitive components which are

connected to power and control lines from over-voltage damage and latch-up caused by Electrostatic Discharging (ESD), Electrical Fast Transients (EFT), Lightning, and Cable Discharge Event (CDE).

AZ4A07-01B is a unique design which includes proprietary clamping cell in a single package. During transient conditions, the proprietary clamping cell prevents over-voltage on the power line or control/data lines, protecting any downstream components.

AZ4A07-01B may be used to meet the ESD immunity requirements of IEC 61000-4-2, Level 4 ( $\pm 15\text{kV}$  air,  $\pm 8\text{kV}$  contact discharge).

## Circuit Diagram / Pin Configuration

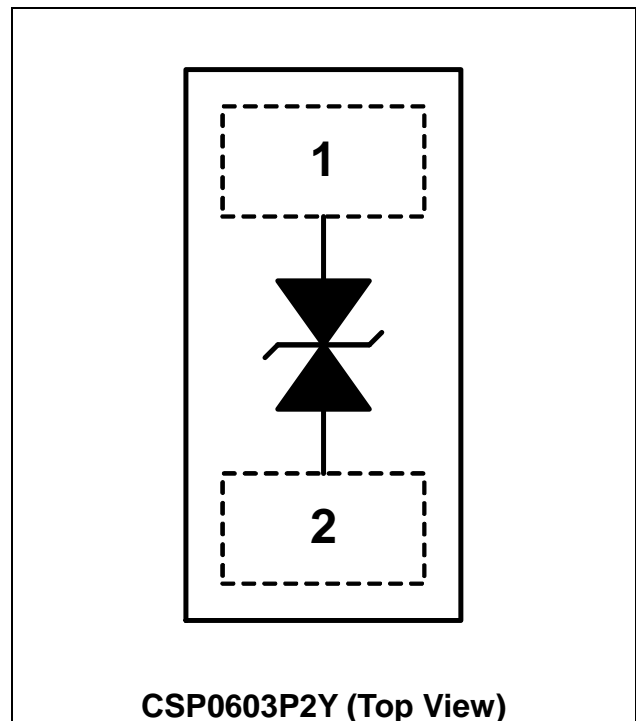



## SPECIFICATIONS

ABSOLUTE MAXIMUM RATINGS (T <sub>A</sub> = 25°C, unless otherwise specified)			
PARAMETER	SYMBOL	RATING	UNITS
Peak Pulse Current (tp=8/20μs)	I <sub>PP</sub>	7	A
Operating Supply Voltage	V <sub>DC</sub>	±7.7	V
ESD per IEC 61000-4-2 (Air)	V <sub>ESD-1</sub>	±30	kV
ESD per IEC 61000-4-2 (Contact)	V <sub>ESD-2</sub>	±30	
Lead Soldering Temperature	T <sub>SOL</sub>	260 (10 sec.)	°C
Operating Temperature	T <sub>OP</sub>	-55 to +125	°C
Storage Temperature	T <sub>STO</sub>	-55 to +150	°C

ELECTRICAL CHARACTERISTICS						
PARAMETER	SYMBOL	CONDITIONS	MINI	TYP	MAX	UNITS
Reverse Stand-Off Voltage	V <sub>RWM</sub>	T=25 °C.	-7		7	V
Reverse Leakage Current	I <sub>Leak</sub>	V <sub>RWM</sub> =±7V, T=25 °C.			100	nA
Reverse Breakdown Voltage	V <sub>BV</sub>	I <sub>BV</sub> =1mA, T=25 °C.	8		10.5	V
Surge Clamping Voltage	V <sub>CL-surge</sub>	I <sub>PP</sub> =5A, tp=8/20μs, T=25 °C.		11		V
ESD Clamping Voltage (Note 1)	V <sub>clamp</sub>	IEC 61000-4-2 +8kV (I <sub>TLP</sub> = 16A), Contact mode, T=25 °C.		13.5		V
ESD Dynamic Turn-on Resistance	R <sub>dynamic</sub>	IEC 61000-4-2 0~+8kV, Contact mode, T=25 °C.		0.27		Ω
Channel Input Capacitance	C <sub>IN</sub>	V <sub>R</sub> = 0V, f = 1MHz, T=25 °C.		50	65	pF

Note 1: ESD Clamping Voltage was measured by Transmission Line Pulsing (TLP) System.

TLP conditions: Z<sub>0</sub>= 50Ω, t<sub>p</sub>= 100ns, t<sub>r</sub>= 1ns.

## Typical Characteristics

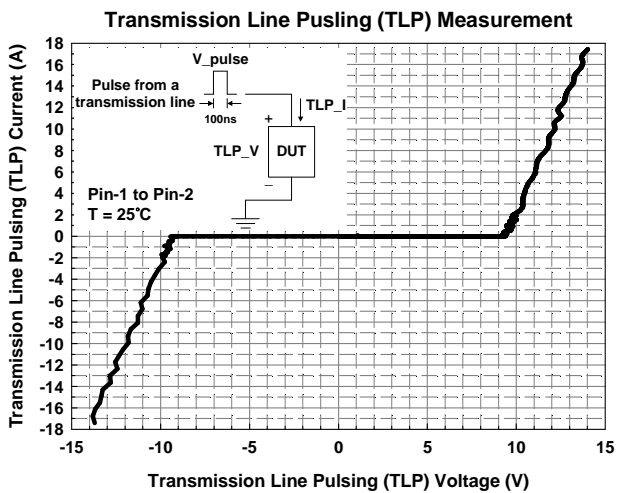
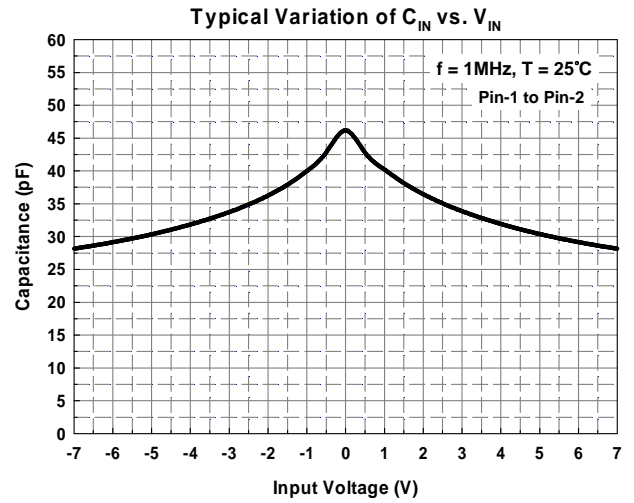
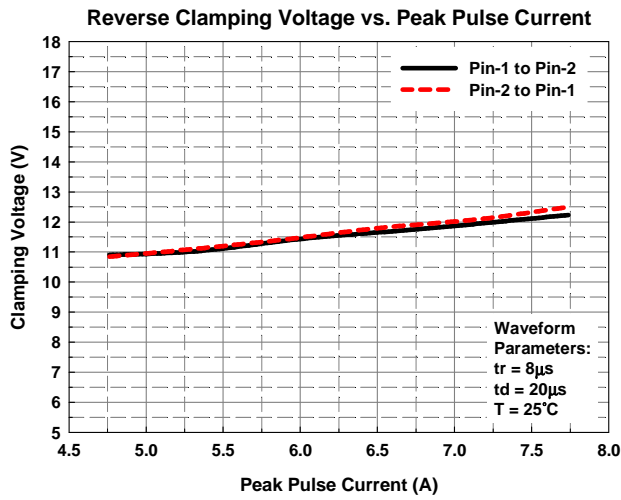



## Applications Information

The AZ4A07-01B is designed to protect one line against System ESD/EFT/Lightning pulses by clamping it to an acceptable reference. It provides bi-directional protection.

The usage of the AZ4A07-01B is shown in Fig. 1. Protected line, such as data line, control line, or power line, is connected at pin 1. The pin 2 is connected to a ground plane on the board. In order to minimize parasitic inductance in the board traces, all path lengths connected to the pins of AZ4A07-01B should be kept as short as possible.

In order to obtain enough suppression of ESD induced transient, good circuit board is critical. Thus, the following guidelines are recommended:

- Minimize the path length between the protected lines and the AZ4A07-01B.
- Place the AZ4A07-01B near the input terminals or connectors to restrict transient coupling.
- The ESD current return path to ground should be kept as short as possible.
- Use ground planes whenever possible.
- NEVER route critical signals near board edges and near the lines which the ESD transient easily injects to.

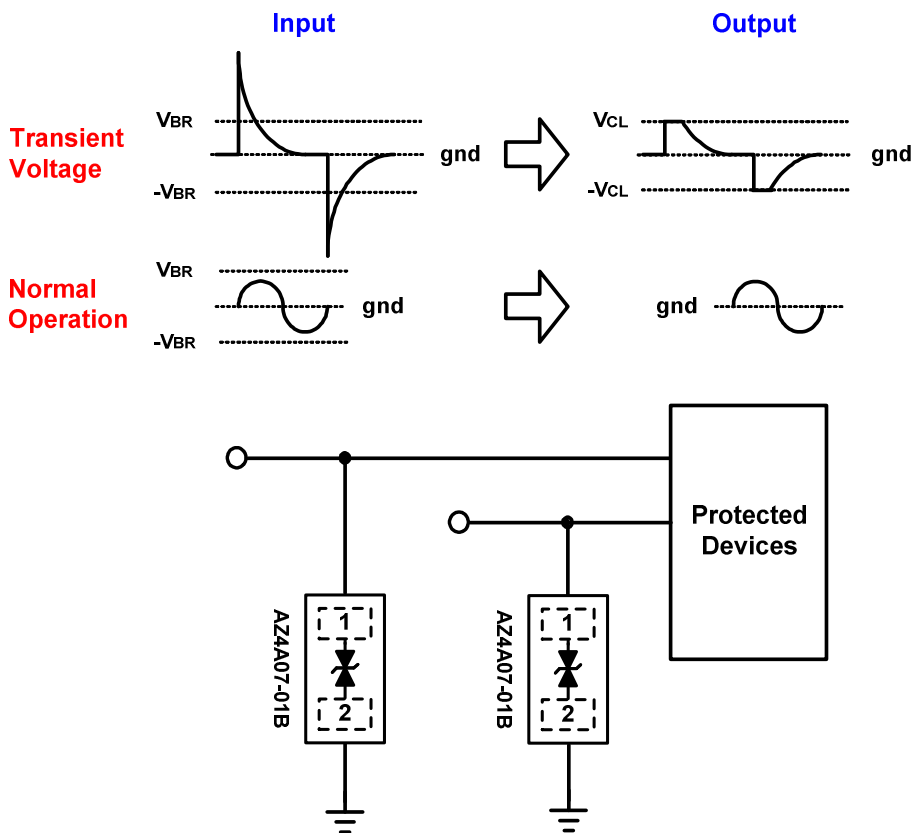
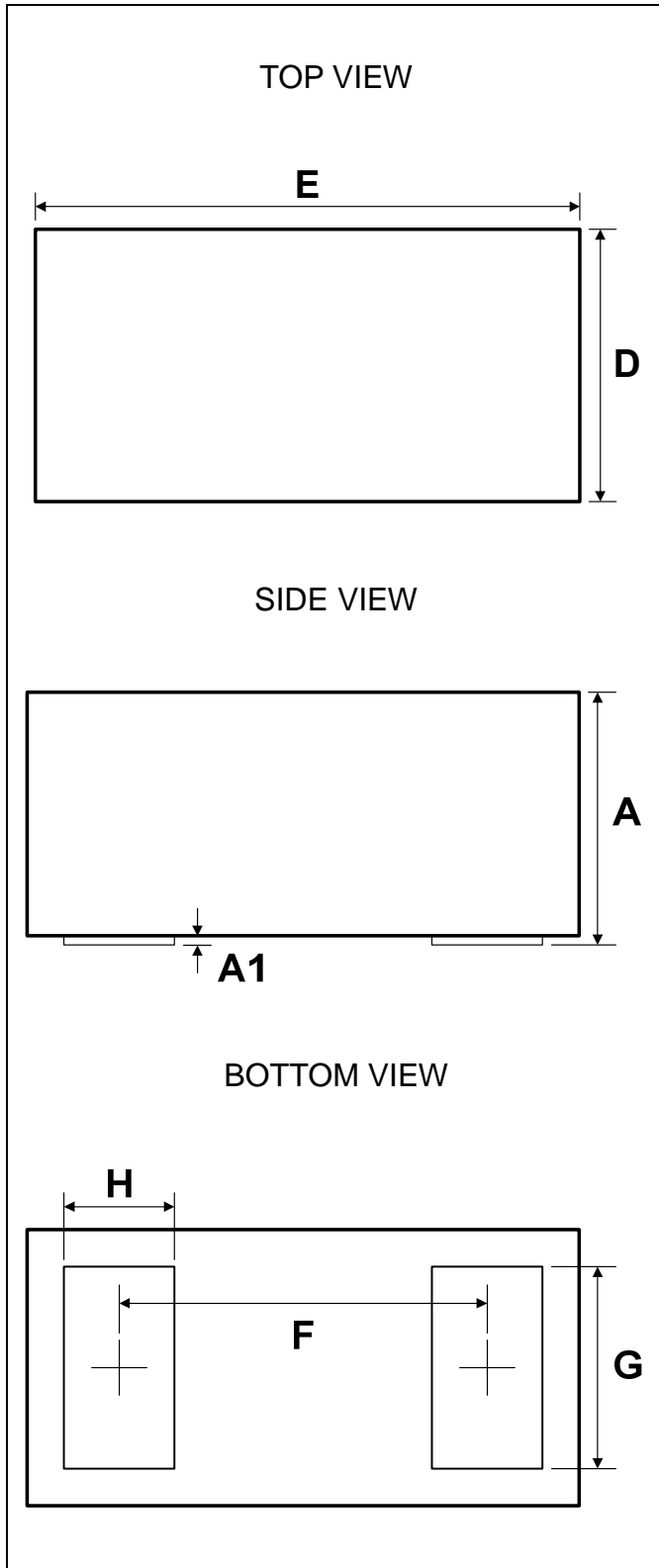

Fig. 1

## Mechanical Details

CSP0603P2Y

### PACKAGE DIAGRAMS



### PACKAGE DIMENSIONS

Symbol	Millimeters		
	MIN.	TYP.	MAX.
<b>D</b>	0.275	0.300	0.325
<b>E</b>	0.575	0.600	0.625
<b>A</b>	0.256	0.276	0.296
<b>A1</b>		0.011	
<b>F</b>		0.400	
<b>G</b>	0.210	0.220	0.230
<b>H</b>	0.110	0.120	0.130

### LAND LAYOUT

Unit: mm

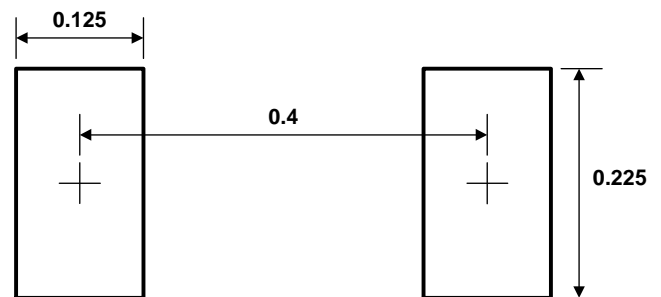

#### Notes:

This LAND LAYOUT is for reference purposes only. Please consult your manufacturing partners to ensure your company's PCB design guidelines are met.

## MARKING CODE

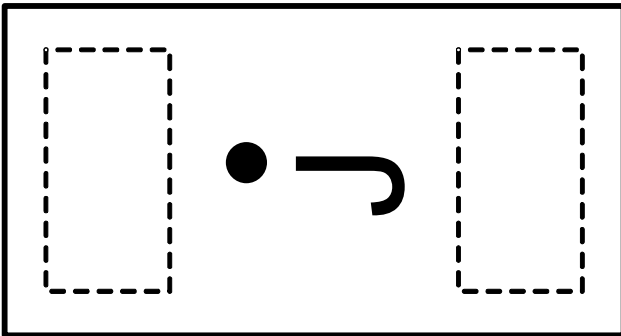

Part Number	Marking Code
AZ4A07-01B.R7G (Green Part)	J

Note : Green means Pb-free, RoHS, and Halogen free compliant.

J = Device Code

## Ordering Information

PN#	Material	Type	Reel size	MOQ	MOQ/internal box	MOQ/carton
AZ4A07-01B.R7G	Green	T/R	7 inch	15,000/reel	4 reels = 60,000/box	6 boxes = 360,000/carton

## Revision History

Revision	Modification Description
Revision 2017/05/08	Formal Release.